

ELCO®

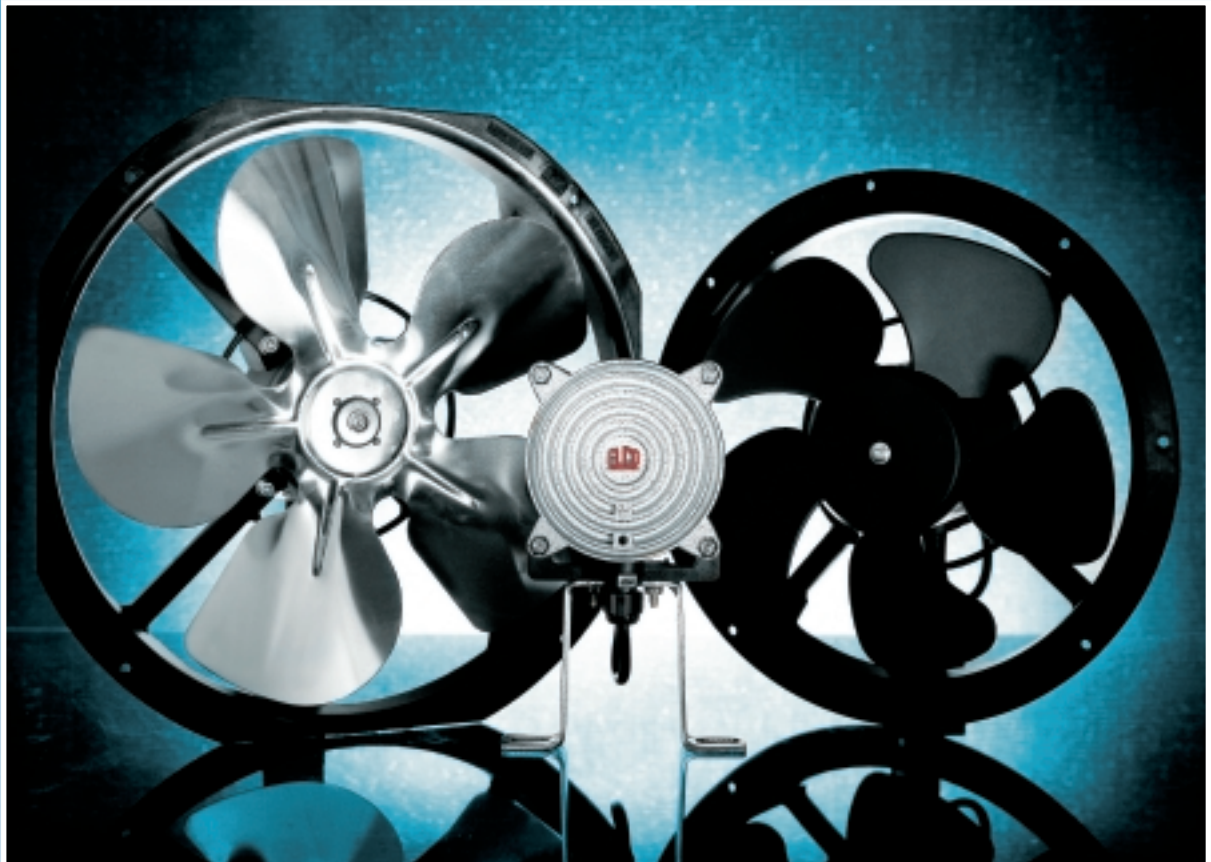

ENERGY SAVING MOTORS

NEW SERIES

ECM IP65-IP66

Our contribution to energy saving and CO₂ emissions reduction



Nowadays, the need to adopt effective actions to promote energy saving, as well as a drastic reduction in CO₂ emissions into the atmosphere, is universally recognised.

In Europe, there are in fact several million of sub-fractional horsepower electric motors used both in domestic appliances, or in air-conditioning and refrigerators. For the latter, especially for the ventilation of refrigerated display cases, sub-fractional HP motors with extremely low efficiency have always been used. For example, approximately 8 Watts of shaft output power are needed to operate a 230 mm diameter fan blade, which can be obtained from the following types of motor:

Shaded poles:
input power ~ 36 Watt
efficiency ~ 18%

Electronically commutated:
input power ~ 12 Watt
efficiency ~ 65%

The importance of choosing a high-efficiency motor is evident from considering a single supermarket with approximately 200 m of refrigerated display units installed, for an estimated total of 200 fan motors.

Considering an average energy cost of 0.11 Euro per kWh and CO₂ emissions of 0.6 kg per kWh consumed, we can calculate that if the same supermarket used "electronic control" motors instead of the equivalent "shaded pole" models, 68,500 kWh could be saved in one year, equivalent to approximately 7,500 Euro and a reduction in CO₂ emissions of **41 tonnes**.

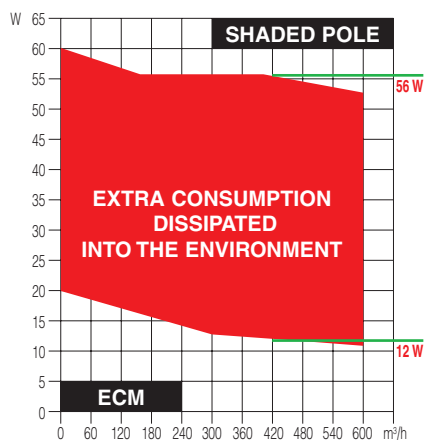

With reference to 16W motor - Ø 254 mm fan

The sensible energy saving widely compensates the greater cost of high-efficiency motors, with payback in just few months: in fact, in the lifetime overall cost of a shaded-pole motor, energy consumption represents almost 97-98%, while its purchase costs only 2-3%.

Moreover, reduced CO₂ emissions is a topic of great interest in relation to the maximum quotas assigned to each country and the related “carbon trading” that regulates the “emission credits” market between virtuous users and less-virtuous ones.

Within this context, thanks to over 800,000 high-efficiency ECM motors already supplied to the market, ELCO has contributed to a reduction in environmental emissions of an estimated **116,000 tonnes of CO₂ per year.**

To confirm the high-efficiency and consequently the cost advantage of ECM motors, a two-months test was carried out by independent consultants at a large foodstore supermarket located in Tortona (Northern Italy), by monitoring a specific area of refrigerated display cases covering approximately 200 fan motors.

Energy consumption was monitored by initially recording the usage of the traditional shaded pole motors and then replacing them with ELCO's ECM models.

Tests results showed a saving of 142,423 kWh against a Total Energy Consumption of 614,466 kWh; the equivalent of approximately **85 tonnes of CO₂.**

Similar tests were carried out in some European supermarkets, where today only ELCO motors are used. The results have not only confirmed large savings, but also more uniform airflow thanks to the greater torque of ECM motors.

The advantages with towards the “shaded pole” solution are:

- **High efficiency 63÷68%**
- **Maximum moisture protection with the new IP65-IP66 versions**
- **Reduced depth compared to the standard N serie Shaded Pole motors**
- **Drop in replacement with the standard N series and possibility to use all standard accessories**

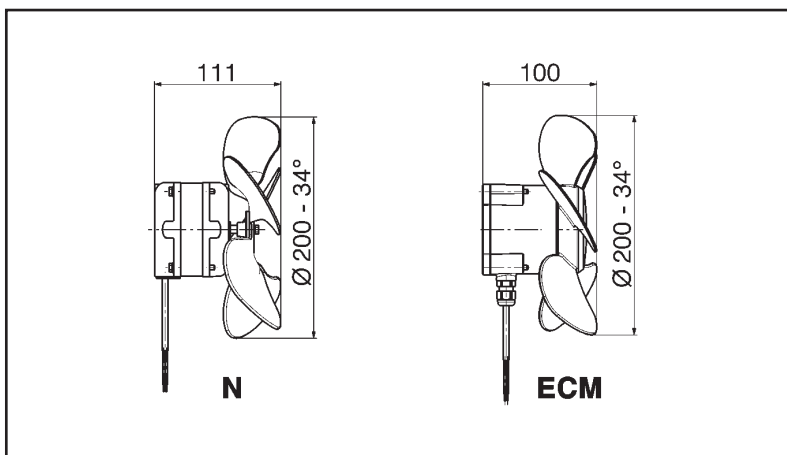

Construction specifications Certifications



General specifications

ELCO SpA has developed and patented a new range of high-efficiency sub-fractional horse power electronically commutated motors - the ECM series. This new generation of motors is specifically designed to satisfy the growing market demands of **“energy saving”**, granting first-rate results in terms of efficiency and life expectancy.

The motor, totally enclosed in a thermoplastic housing, contributes to limiting external heat emission, which results in a particularly cool motor body during operation and hence generate a further energy savings. Thanks to a special, permanent lubrication system and based on laboratory tests, the life expectancy is approximately 30,000 hours for the Standard version and 60,000 hours for the Long Life version.

The ECM series is currently available in two single-speed versions, to be selected according to power requirements.

Type	Protection Rating	Bearing	Rear shield
Standard	IP65	Sleeve-bearings	Plastic
Long-Life	IP65	Ball-bearings	Plastic
Long-Life	IP66	Ball-bearings	Plastic
Long Life	IP66	Ball-bearings	Aluminium*

IP65 moulded cable grommet

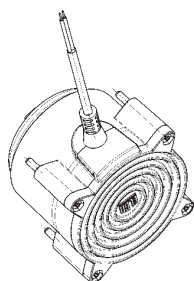

IP66 cable strain relief

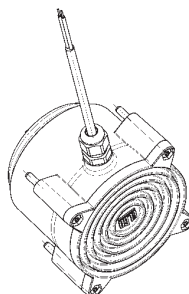

***IP66** with rear mounting

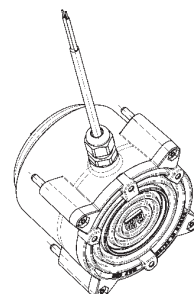

Certifications







All products are designed and manufactured according to European regulations CENELEC EN 60335-1, electromagnetic compatibility EN 61000-3-2 +A1/A2, EN55014-1 and CE marked.

All components are UL compliant.

UL XEIT listed versions are available.



Technical data

	ECM Standard	ECM Long Life
Working temperature with: Plastic fan	-20°C ÷ +55°C*	
Aluminium fan	-30°C ÷ +55°C*	
Insulation class	B	
Protection rating	IP65	IP65-IP66
Voltage	100V / 50÷60HZ • 115-127V / 50÷60Hz • 230-240V / 50÷60Hz	
RPM at 100V	1400	
RPM at 115-127V	1450 • 1550 • 1850	
RPM at 230-240V	1400 • 1600 • 1850	
IN power	9÷14W	9÷14W • 20÷25W
Standards	CENELEC EN 60335-1 • EN 61000-3-2 + A1/A2 • EN 55014-1	
Approvals	  	  
Supports	Sleeve-bearings	Ball-bearings
Life expectancy at 20°C	30,000 hours	60,000 hours

* > 55°C upon request ** Approval pending

Applications



N Fan

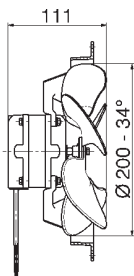

ECM Fan

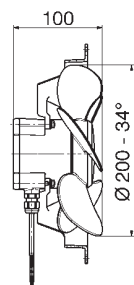

The ECM series motors may be universally applied, but are particularly suited to the refrigeration and ventilation industry, especially for refrigerated display cases, freezers, drink dispensers and small condensers; they can be coupled with various types of fan blades, particularly axial fans with diameters up to 300 mm.

Interchangeability:

The ECM motor was also designed to comply with the same principle of standardization that ELCO developed for the N-series motors.

In fact, ELCO's "**energy saving**" motors are, drop-in replacements of the traditional shaded pole ones, and use all the same accessories, such as brackets, fans, rings and guards, with no extra work - or hidden costs, to the full benefit of rapidity and convenience.



Construction differences

IP65 Standard

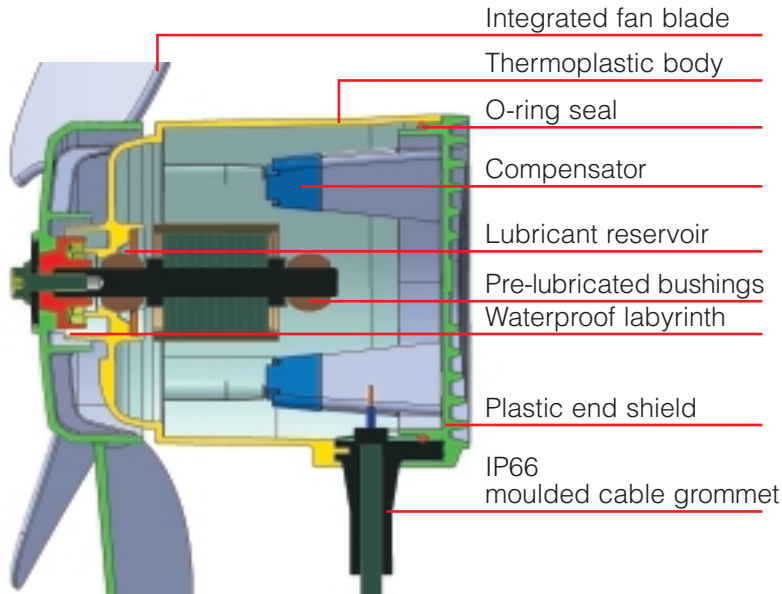

IP66 Long Life

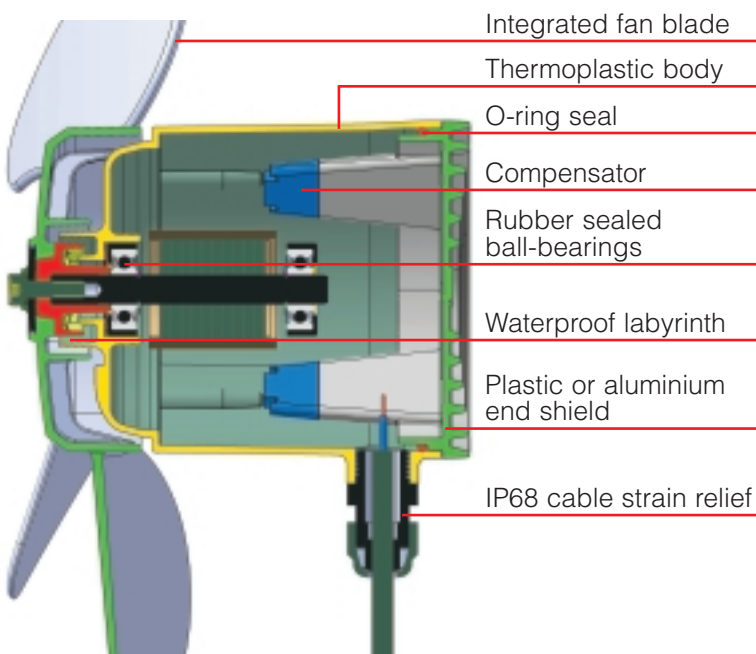

Product description:

The ECM IP65 and IP66 Series is a new product, derived from the well-known range of **energy-saving** motors and designed for operation in environments with high humidity or moisture.

The IP65 version comes with an O-ring to seal the rear plastic end-shield to the motor housing and moulded cable grommet, sleeve or ball-bearings and a new fan profile integrated with the internal watherproof labyrinth.

While in the IP66 version, the motor has a double-sided rubber sealed ball-bearings and cable exit fitted with an IP68 strain relief.

The electronic control unit is provided with various safety features:

- Overload control function, which switches the motor to standby mode if an external mechanical action causes the speed to drop below a preset level.
- Locked rotor control function, which switches the motor to standby mode after twenty restart attempts, in case of fan blocked by icing or other reasons.
- Auto-reset function, which allows the microprocessor to reset and restart the control functions, in cases of electrical interference or power supply fluctuations.
- Self-diagnostics function during switch-on and switch-off. In cases of ON/OFF alternative use, each cycles should be at least 20 seconds apart.
- Power shut-down function in cases of microprocessor failure.

Overall dimensions

With integrated fan

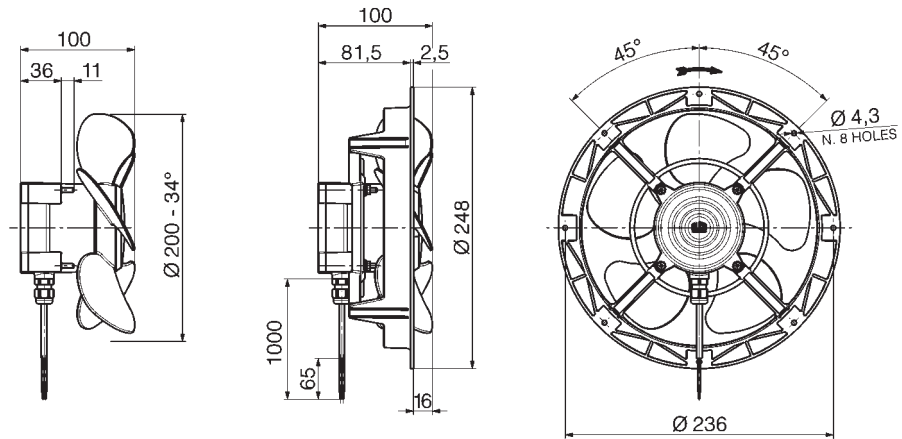

With Aluminium/Plastic fan

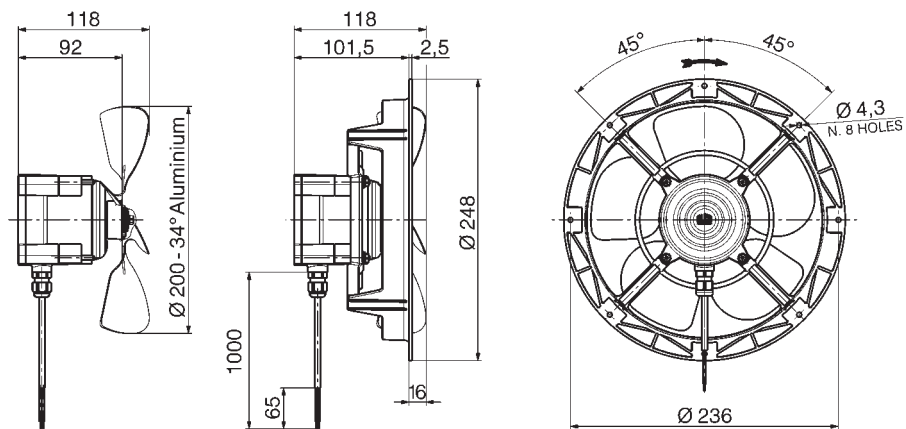

Spacers to adjust the X distance

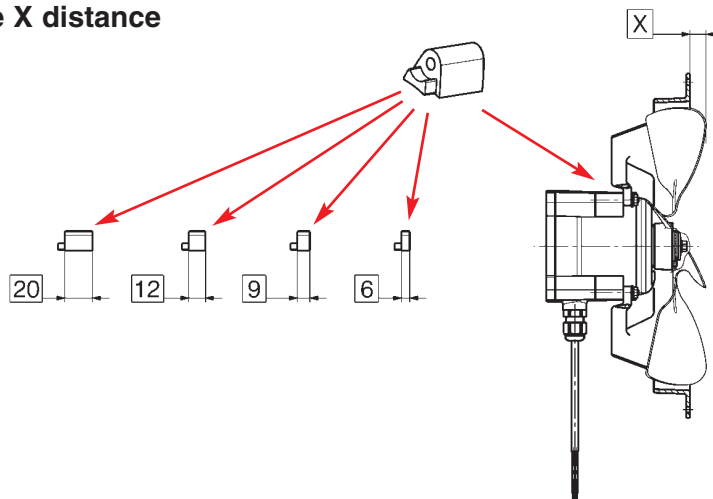

Fan assembly Accessory

With integrated fan

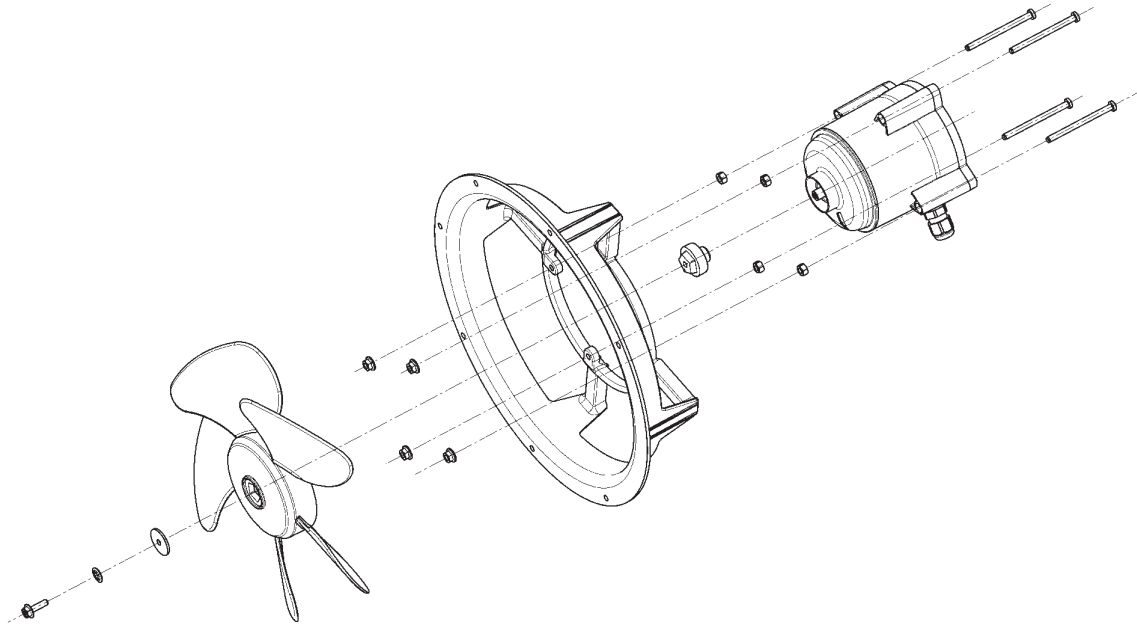

With adapter for aluminium or plastic fan

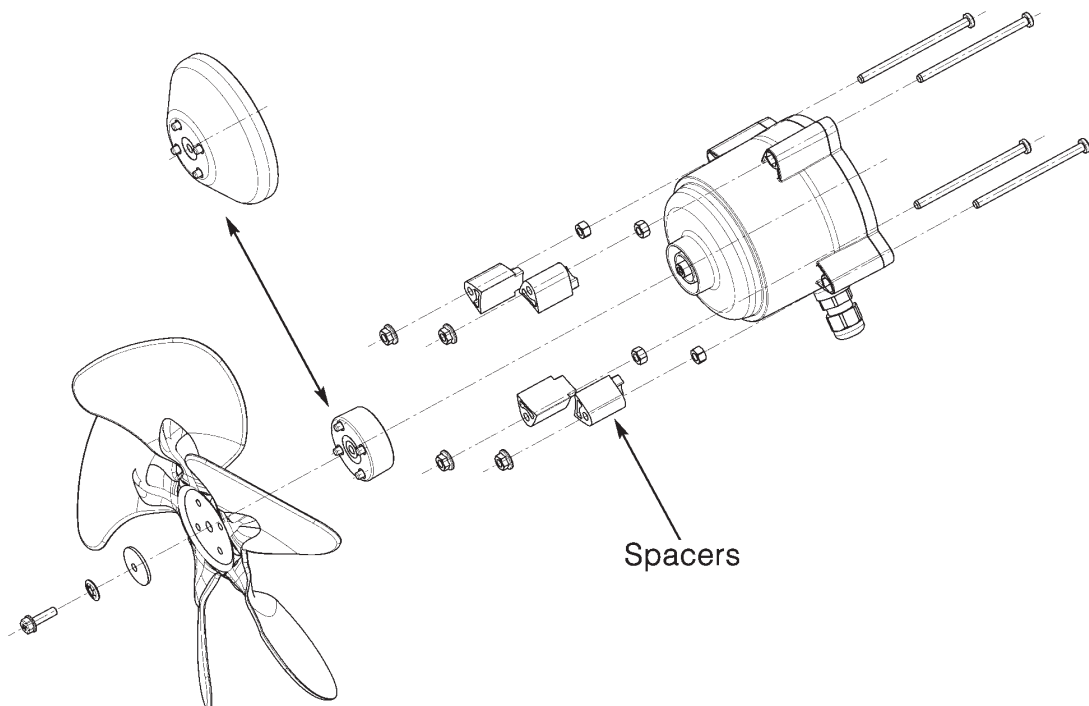

Mountings

ECM with integrated fan and bracket

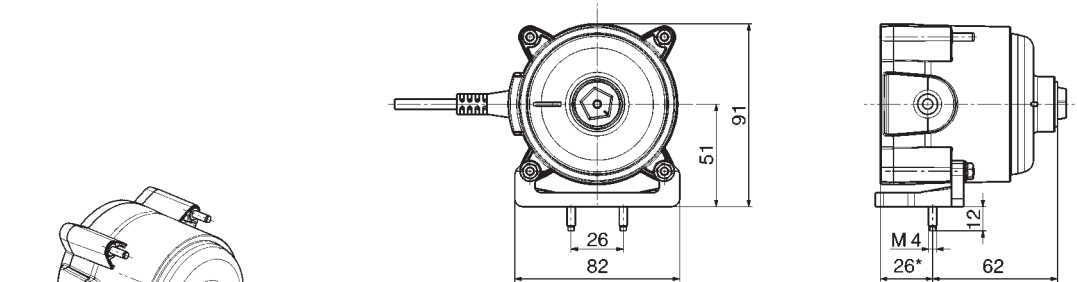

ECM with aluminium or plastic fan and bracket

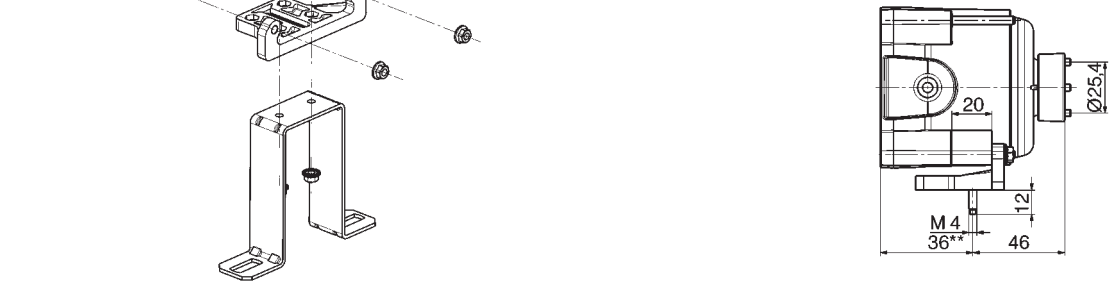

* 36 for greater power ratings
 ** 46 for greater power ratings

Comparison of overall dimensions with bracket

N
Aluminium/Plastic Fan

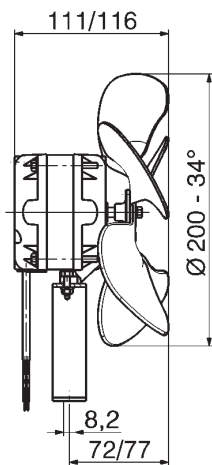

ECM
Integrated Fan

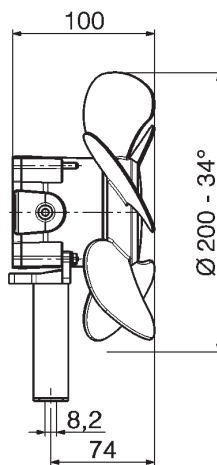

ECM
Aluminium/Plastic Fan

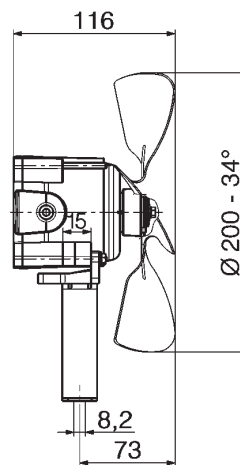

Fans

ECM 12W 1400 Rpm

ECM 25W 1400 Rpm

Integrated plastic fan

		Fan Ø					
Type		154	172	200	230	254	
VMA	19°				19°		
						22°	
					25°		
		28°	28°				
					31°		
			34°				



Plastic fan with fan hub

		Fan Ø						
Type		140	154	172	200	222	230	254
VEA								22°
							25°	
	28°	28°		28°			28°	28°
			31°		31°	31°		
VEP								19°
		19°						25°
	28°							
				31°				



Aluminium fan with fan hub and silencer

		Fan Ø						
Type		154	172	200	230	254	275	300
A	19°	19°	19°	19°	19°	19°		19°
	22°	22°	22°	22°	22°	22°	22°	
	25°	25°	25°	25°	25°	25°	25°	
	28°	28°	28°	28°	28°	28°		
	31°	31°	31°	31°	31°	31°		
	34°	34°	34°	34°	34°	34°		
AO	19°	19°	19°	19°	19°	19°		19°
	22°	22°	22°	22°	22°	22°		
	25°	25°	25°	25°	25°	25°	25°	
	28°	28°	28°	28°	28°	28°		
	31°	31°	31°	31°	31°	31°		
	34°	34°	34°	34°	34°	34°		





ELCO S.p.A.

Via Marconi, 1
20065 INZAGO Milano - Italy
Phone +39 02 95319.1
Fax +39 02 95310138
www.elco-spa.com
e-mail: info@elco-spa.com

